

Voľnobežné spojky

GV

Tolerancia hriadeľa h6

$T_{MAX} = 2,5 \times T_N$

Drážka pre pero GV 20-120 DIN 6885

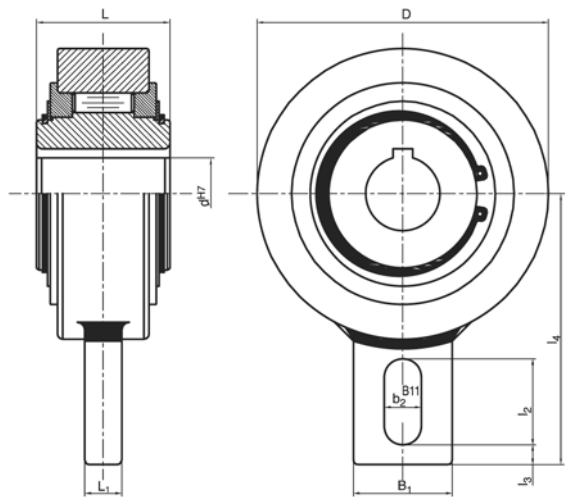

Typ	^{H7} [mm]	D [mm]	L [mm]	B ₁ [mm]	L ₁ [mm]	b ₂ [mm]	l ₂ [mm]	l ₃ [mm]	l ₄ [mm]	Hmotnosť [kg]	Vnútorný krúžok n [min ⁻¹] ^{*1}	T _N [Nm]	Stratový krútiaci moment [Nm]
GV 20	20	83	35	40	12	15	35	5	90	1,3	450	220	0,2
GV 25	25	83	35	40	12	15	35	5	90	1,3	450	220	0,2
GV 30	30	118	54	40	15	15	35	8	110	3,5	320	1000	1,2
GV 35	35	118	54	40	15	15	35	8	110	3,4	320	1000	1,2
GV 40	40	118	54	40	15	15	35	8	110	3,3	320	1000	1,2
GV 45	45	155	54	80	15	18	35	10	140	5,8	300	1750	2,2
GV 50	50	155	54	80	15	18	35	10	140	5,7	300	1750	2,2
GV 55	55	155	54	80	15	18	35	10	140	5,6	300	1750	2,2
GV 60	60	155	54	80	15	18	35	10	140	5,5	300	1750	2,2
GV 70	70	155	54	80	15	18	35	10	140	5,3	300	1750	2,2
GV 80	80	190	64	80	20	20	40	20	155	8,7	200	2350	3,5
GV 90*	90	260	90	120	25				220	24,5	150	5800	3,5
GV 100*	100	260	90	120	25				220	23,5	150	5800	3,5
GV 110*	110	260	90	120	25				220	22,5	150	5800	3,5
GV 120*	120	300	110	140	30				220	42,0	130	8900	6,0

*1 Maximálna povolená rýchlosť

*Dve drážky pre pero v 120°

Príklad montáže

